

## DISMANTLING JOINT T-KC (F4)

Nominal pressure:  
**PN 10**

Flange connection:  
**DIN 2632**

Hygienic cert. PZH:  
**HK/W/0041/01/2011**

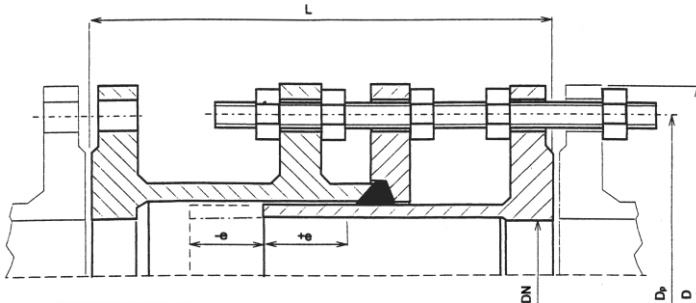

### Special material:

1.4301 = AISI 304 = 0H18N9 = A2  
 1.4401 = AISI 316 = 0H17N12M2 = A4  
 1.4541 = AISI 321 = 1H18N9T  
 1.4571 = AISI 316 Ti = 0H17N13M2T = A4

**Dismantling Joint T-KC (F4)**, lockable pieces, designed for installation and removal of fittings and valves.

Sealing: EPDM

Material: Carbon Steel St3s (St37-2, S235 JR)

Bolts (DIN 957) and Nuts: zinc plated

Anticorrosion protection (OPTIONS):

- internally and externally coated with bitumen, admitted to contact with drinking water
- inside and outside zinc plated
- epoxy powder coating EKB (electrostatic plastic coating, according to RAL-G2662)

DN	L [mm] body length	+/-e	D [mm]	Dp [mm]	M threaded rod	i [pcs.] qty. of bolts	Weight [kg]
32	300	25	140	100	16	4	11
40	300	25	150	110	16	4	12,5
50	300	25	165	125	16	4	15
65	300	25	185	145	16	4	18
80	300	25	200	160	16	8	22,5
100	300	25	220	180	16	8	28
125	300	25	250	210	16	8	34
150	350	25	285	240	20	8	48
175	350	25	315	270	20	8	56
200	350	25	340	295	20	8	64
250	350	25	395	350	20	12	88
300	350	25	445	400	20	12	103
350	350	25	505	460	20	16	125
400	375	25	565	515	24	16	160
450	375	25	615	565	24	20	176
500	375	25	670	620	24	20	198
550	400	25	730	675	27	20	248
600	400	25	780	725	27	20	268
650	400	25	835	780	27	24	292
700	400	25	895	840	27	24	335
800	450	25	1015	950	30	24	455
900	450	25	1115	1050	30	28	522
1000	475	25	1230	1160	33	28	635
1100	475	25	1340	1270	33	32	744
1200	525	25	1455	1380	36	32	984
1300	550	25	1575	1490	39	32	1185
1400	550	25	1675	1590	39	36	1256
1500	550	25	1785	1700	39	36	1472
1600	600	25	1915	1820	45	40	1895
1800	650	25	2115	2020	45	44	2305
2000	700	25	2325	2230	45	48	2800
2200	700	25	2550	2440	52	52	3488
2400	700	25	2760	2650	52	56	4080

- SPECIAL PERFORMANCE ON REQUEST -